

ITEM #	DESCRIPTION	MATERIAL
*1	BODY, VALVE	CAST IRON, A-126, CLASS B WITH 316 STAINLESS STEEL SEAT
*2	VANE	CAST IRON, A-48, CLASS 40
3	COVER, END	CAST IRON, A-126, CLASS B
4	SEAT RING, VANE	EPDM WITH 304 STAINLESS STEEL INSERT
5	SHAFT, OPERATOR	304 STAINLESS STEEL, ASTM A-276
6	SHAFT, THRUST	304 STAINLESS STEEL, ASTM A-276
7	BUSHING	REINFORCED TEFLON
8	STUD	A307 STEEL (STANDARD)/304 SS (OPTIONAL)/316 SS (OPTIONAL)
9	NUT, HEX	A307 STEEL (STANDARD)/304 SS (OPTIONAL)/316 SS (OPTIONAL)
10	TORQUE PLUG, SHAFT	304 STAINLESS STEEL, ASTM A-276
11	CAPSCREW, HEX	STAINLESS STEEL, 18-8 WITH NYLOK INSERT
12	BOLT, HEX HEAD	A307 STEEL (STANDARD)/304 SS (OPTIONAL)/316 SS (OPTIONAL)
13	O-RING, END COVER	BUNA-N
14	SHAFT SEAL	BUNA-S
15	SEAL RING	STEEL, C-1018
16	THRUST COLLAR	BEARING BRONZE, UNS C93200
17	ROLL PIN	STAINLESS STEEL, A.I.S.I. 420



KENNEDY VALVE

Division of McWane, Inc.
1021 EAST WATER STREET ELMIRA, NEW YORK 14901

DWN: D SKAKAL

DATE: 5/23/17

DWG. NO.

CAT914C10034-01

14" THRU 20" STYLE 4500
CLASS 150 BUTTERFLY VALVE
SUB-ASSEMBLY / MATERIAL LIST
WAFER ENDS

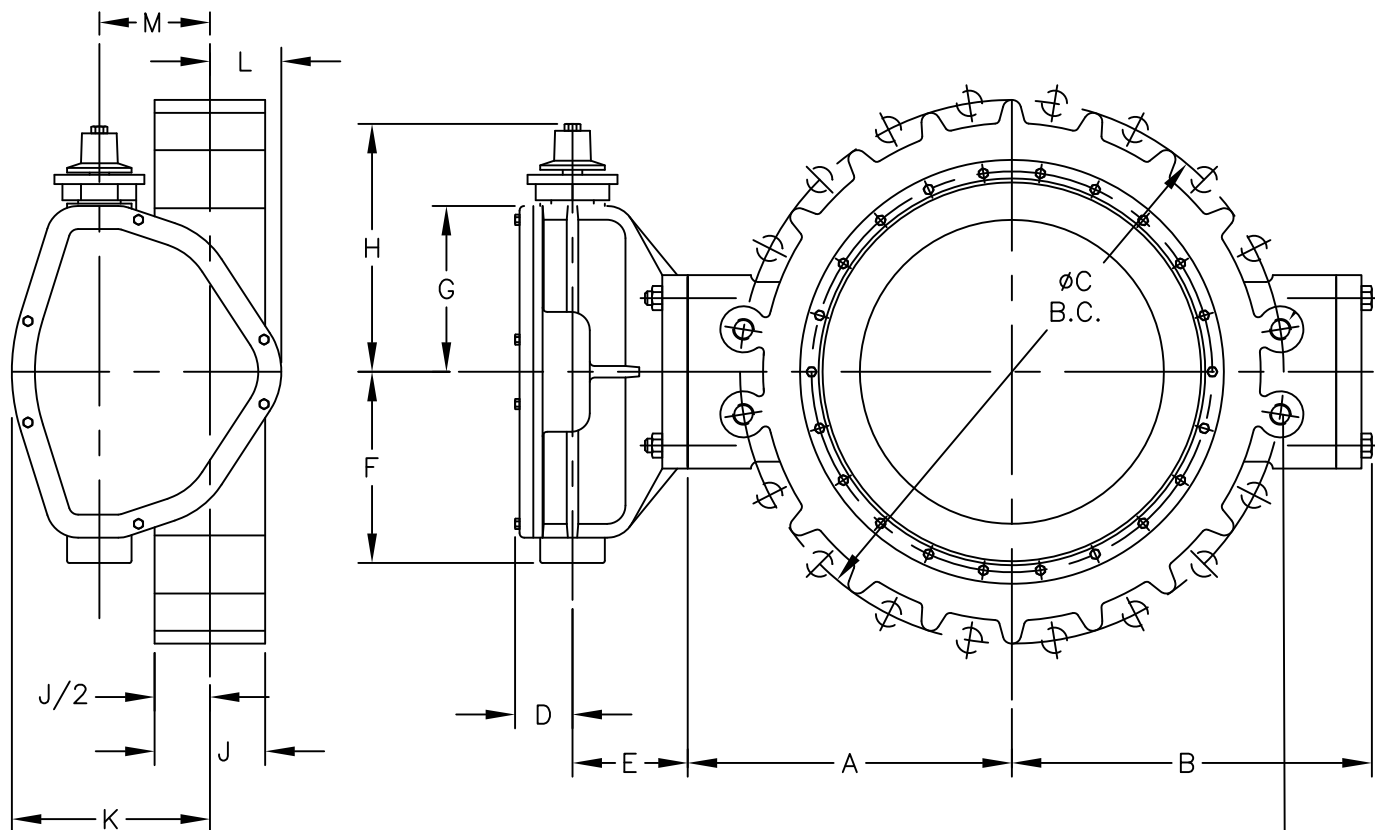

FOR INSTALLATION BETWEEN
125# OR 150# ASA FLANGES

FOUR HOLES, "AB" DIAMETER
(18" & 20" ONLY, THESE FOUR
HOLES ARE TAPPED "AB" X
"AD" DEEP EACH FACE)

VALVE SIZE	OPERATOR MODEL	D	E	F	G	H	K	L	M	N
4"	65	2	3 9/16	3 5/8	3	7 3/4	3 7/16	2 1/4	1 3/8	16 1/2
6"	150	2	3 9/16	3 5/8	3	7 3/4	3 7/16	2 1/4	1 3/8	16 1/2
8"	250	2 1/8	3 11/16	4 1/4	3 7/8	8 3/4	4 1/2	2 3/8	2	24
10" & 12"	510	2 3/8	4 1/2	5 9/16	5 3/16	10 1/2	6 1/8	2 3/4	3 1/8	36
14",16",18" & 20"	1250	3 3/16	5 3/4	8 3/8	7	12 5/16	7 7/8	3 1/4	4	48

VALVE SIZE	A	B	C	J	P	Q	AB	AD	WEIGHT
4"	4	5 1/8	7 1/2	2 1/2	8	5/8	-	-	60
6"	5	6 1/8	9 1/2	2 17/32	8	3/4	-	-	70
8"	6	7 3/8	11 3/4	2 25/32	8	3/4	-	-	100
10"	7 3/4	9 1/2	14 1/4	3 1/4	12	7/8	-	-	155
12"	9 1/2	10 7/8	17	3 9/32	12	7/8	-	-	190
14"	10 7/16	12 3/16	18 3/4	4 1/2	12	1	-	-	405
16"	12 3/16	13 15/16	21 1/4	4 1/2	16	1	-	-	465
18"	13 5/16	15 1/16	22 3/4	5 3/4	16	1 1/8	1 1/8-7	1 3/8	595
20"	14 7/8	16 5/8	25	5 3/4	20	1 1/8	1 1/8-7	1 1/4	675

NOTE 1: FLOW MAY BE IN EITHER DIRECTION

NOTE 2: VALVE SHAFT WILL MEET OR EXCEED REQUIREMENTS OF SHAFT TABLE PER AWWA STANDARD C-504 FOR APPLICABLE CLASS.

NOTE 3: REFERENCE AWWA C-504 FLANGES & DRILLING (A.N.S.I. 125)

NOTE 4: "N" = NUMBER OF TURNS TO CLOSE

NOTE 5: "P" = NUMBER OF BOLTS ON EACH FLANGE

NOTE 6: "Q" = DIAMETER OF BOLTS

NOTE 7: OPERATED BY 2" AWWA OPERATING / WRENCH NUT



KENNEDY VALVE

Division of McWane, Inc.
1021 EAST WATER STREET ELMIRA, NEW YORK 14901

DWN: D SKAKAL

DATE: 5/23/17

DWG. NO.

CAT914C10035-01

4" THRU 20" STYLE 4500
CLASS 150 BUTTERFLY VALVE
BURIED OPERATOR
WAFER ENDS

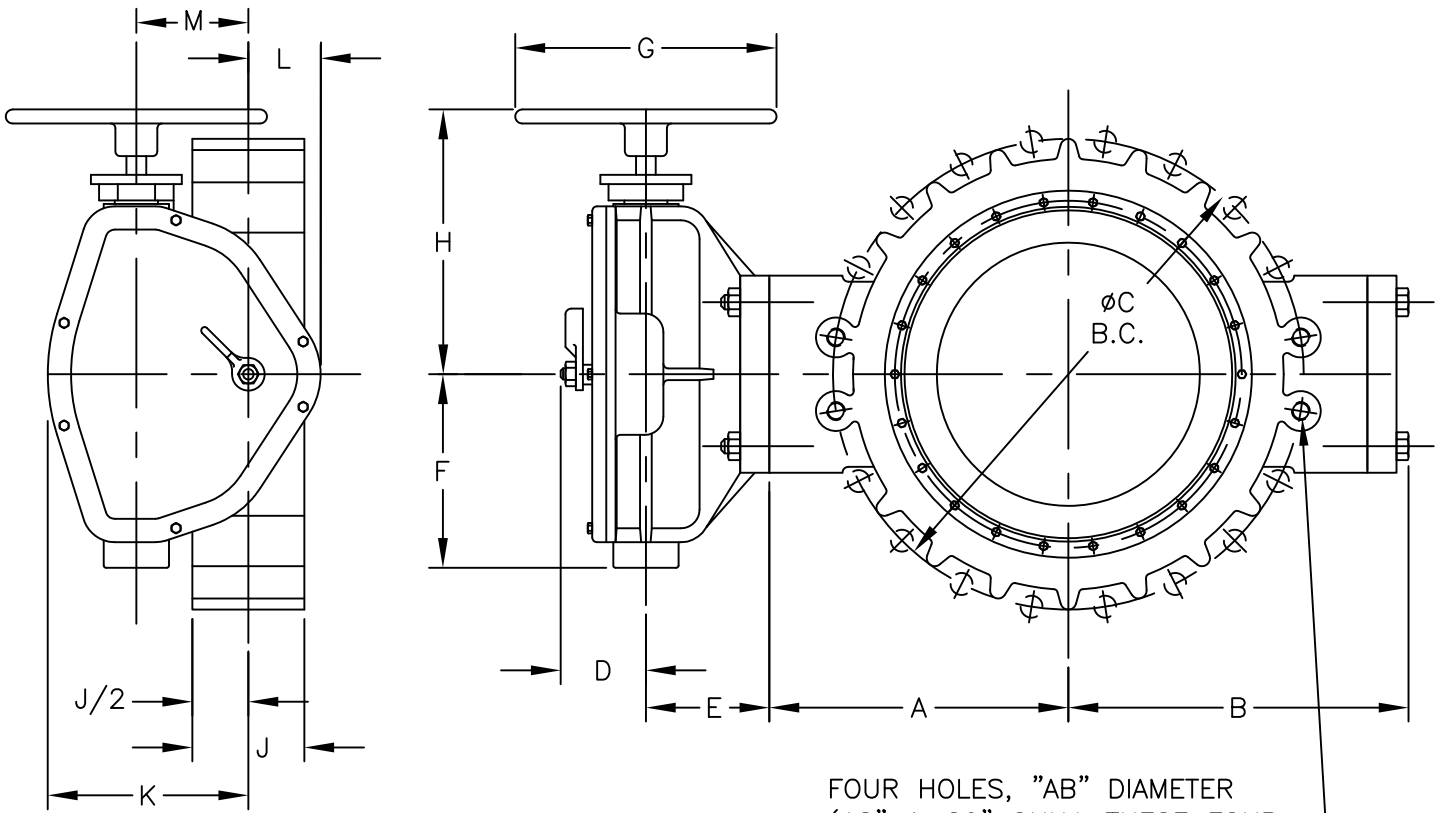

FOR INSTALLATION BETWEEN
125# OR 150# ASA FLANGES

FOUR HOLES, "AB" DIAMETER
(18" & 20" ONLY, THESE FOUR
HOLES ARE TAPPED "AB" X
"AD" DEEP EACH FACE)

VALVE SIZE	OPERATOR MODEL	D	E	F	G	H	K	L	M	N
4"	65	2 15/16	3 9/16	3 5/8	7 1/2	7 3/4	3 7/16	2 1/4	1 3/8	16 1/2
6"	150	2 15/16	3 9/16	3 5/8	7 1/2	7 3/4	3 7/16	2 1/4	1 3/8	16 1/2
8"	250	3	3 11/16	4 1/4	14	8 3/4	4 1/2	2 3/8	2	24
10" & 12"	510	3 3/16	4 1/2	5 9/16	14	10 1/2	6 1/8	2 3/4	3 1/8	36
14", 16", 18" & 20"	1250	4 3/16	5 3/4	8 3/8	18	12 5/16	7 7/8	3 1/4	4	48

VALVE SIZE	A	B	C	J	P	Q	AB	AD	WEIGHT
4"	4	5 1/8	7 1/2	2 1/2	8	5/8	-	-	60
6"	5	6 1/8	9 1/2	2 17/32	8	3/4	-	-	70
8"	6	7 3/8	11 3/4	2 25/32	8	3/4	-	-	100
10"	7 3/4	9 1/2	14 1/4	3 1/4	12	7/8	-	-	155
12"	9 1/2	10 7/8	17	3 9/32	12	7/8	-	-	190
14"	10 7/16	12 3/16	18 3/4	4 1/2	12	1	-	-	405
16"	12 3/16	13 15/16	21 1/4	4 1/2	16	1	-	-	465
18"	13 5/16	15 1/16	22 3/4	5 3/4	16	1 1/8	1 1/8-7	1 3/8	595
20"	14 7/8	16 5/8	25	5 3/4	20	1 1/8	1 1/8-7	1 1/4	675

NOTE 1: FLOW MAY BE IN EITHER DIRECTION

NOTE 2: VALVE SHAFT WILL MEET OR EXCEED REQUIREMENTS OF SHAFT TABLE PER AWWA STANDARD C-504 FOR APPLICABLE CLASS.

NOTE 3: REFERENCE AWWA C-504 FLANGES & DRILLING (A.N.S.I. 125)

NOTE 4: "N" = NUMBER OF TURNS TO CLOSE

NOTE 5: "P" = NUMBER OF BOLTS ON EACH FLANGE

NOTE 6: "Q" = DIAMETER OF BOLTS



KENNEDY VALVE

Division of McWane, Inc.
1021 EAST WATER STREET ELMIRA, NEW YORK 14901

DWN: D SKAKAL

DATE: 5/23/17

DWG. NO.

CAT914C10036-01

4" THRU 20" STYLE 4500
CLASS 150 BUTTERFLY VALVE
HANDWHEEL OPERATOR
WITH POSITION INDICATOR
WAFER ENDS

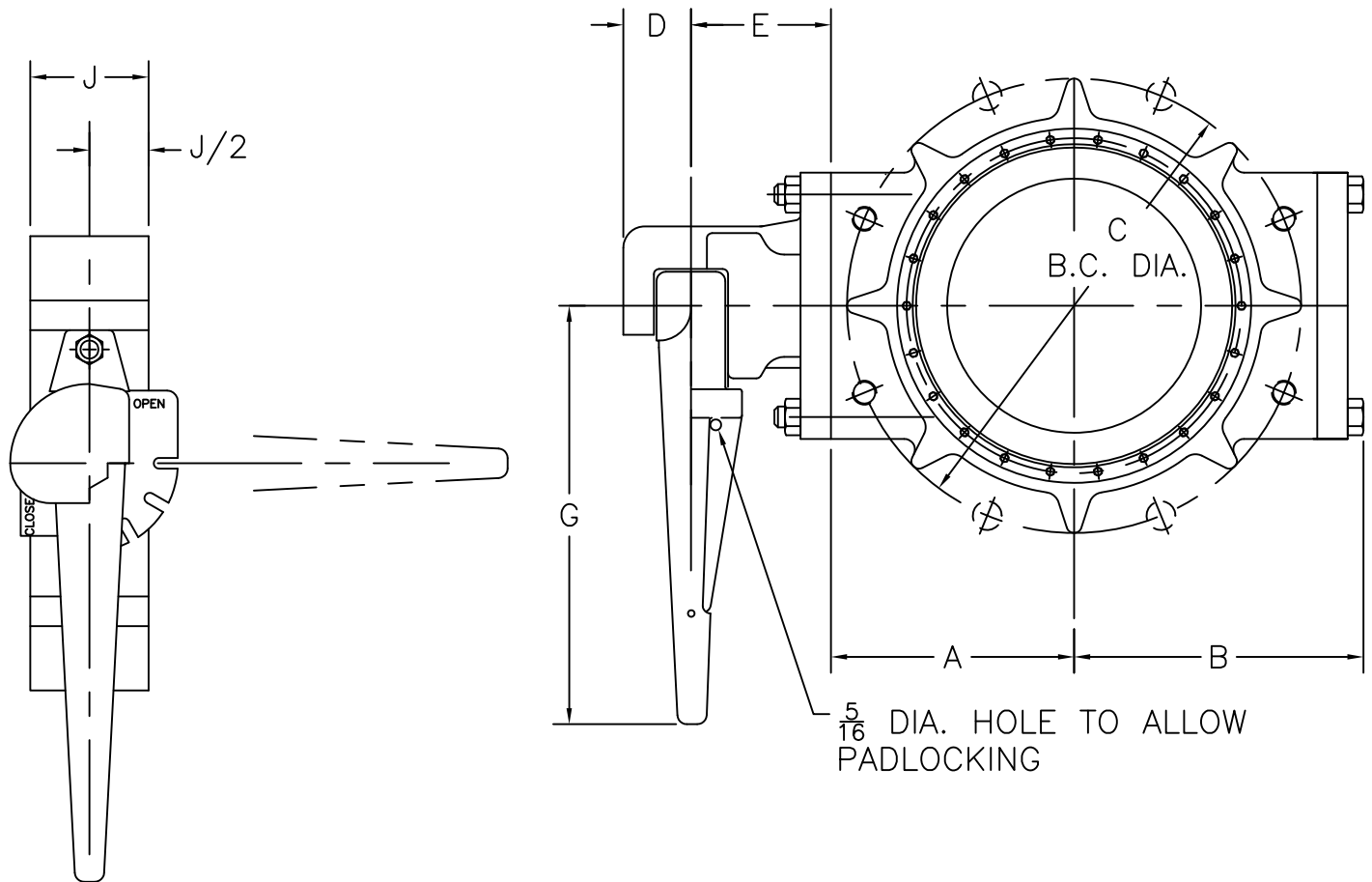

VALVE SIZE	OPERATOR MODEL	D	E	G
4"	150	1 1/2	3 13/16	11
6"	150	1 1/2	3 13/16	11
8"	150	1 1/2	3 13/16	11

VALVE SIZE	A	B	C	D	E	G	J	P	Q	WEIGHT
4"	4	5 1/8	7 1/2	1 1/2	3 13/16	11	2 1/2	8	5/8	40
6"	5	6 1/8	9 1/2	1 1/2	3 13/16	11	2 17/32	8	3/4	55
8"	6	7 3/8	11 3/4	1 1/2	4 1/16	11	2 25/32	8	3/4	65

- NOTE 1: FLOW MAY BE IN EITHER DIRECTION
 NOTE 2: VALVE SHAFT WILL MEET OR EXCEED REQUIREMENTS OF SHAFT TABLE PER AWWA STANDARD C-504 FOR APPLICABLE CLASS.
 NOTE 3: REFERENCE AWWA C-504 FLANGES & DRILLING (A.N.S.I. 125)
 NOTE 4: "P" = NUMBER OF BOLTS ON EACH FLANGE
 NOTE 5: "Q" = DIAMETER OF BOLTS



KENNEDY VALVE
 Division of McWane, Inc.
 1021 EAST WATER STREET ELMIRA, NEW YORK 14901

DWN: D SKAKAL
 DATE: 5/23/17
 DWG. NO.
 CAT914C10037-01

4" THRU 8" STYLE 4500
 CLASS 150 BUTTERFLY VALVE
 LEVER OPERATOR
 WAFER ENDS