



# RESILIENT SEATED GATE VALVES

KENNEDY SERIES 324

to EN/ISO Standards

Kennedy Gate Valves, with their unique features, have been used in the water transmission and fire protection industries since 1877. Our series 324 gate valves conform to EN/ISO standards and are designed to maintain the high quality and integrity of existing designs while incorporating many superior features. Series 324 valves are ductile iron with fully encapsulated rubber discs for a bubble tight shut off. Valves are designed with ISO top flange mounting pads for gears/actuators, and are suitable for water and neutral liquids to a maximum operating temperature of 70° C.



### General Specifications

Type: Resilient Seated Ductile Iron Gate Valves  
Non Rising Stem, Meets EN Standards  
with ISO top flanges

Sizes : DN 50 - DN 300  
Working Pressure: 16 Bar

### Models

324 : Face to Face ISO 5752 Series 14  
Top Flange to ISO 5210

### Flanges

EN 1092-2 PN16

### Face to Face

EN 558 & ISO 5752 standards

### Test Pressure

Pressure Testing to EN 1074 - 1&2 and EN 12266-1&2  
Seat Test : 1.1 x PN ( 18 Bar)  
Body Test : 1.5 x PN ( 24 Bar)

### Coating

Fusion bonded non-toxic epoxy coating NSF 61  
Coated to DIN 30677-2 Standards  
Bolts are seated with hot melt

### Options

Gear Operators  
Electric Actuators  
Alternative flange drilling

### Material Specifications ( Trim 301)

Body & Bonnet	: Ductile Iron EN 1563 to EN JS 1050	O Rings	: EPDM
Wedge	: EPDM encapsulated Ductile Iron	Thrust Collar	: Copper Alloy, Bronze CW 453K
Stem	: Stainless Steel 316	Bonnet Gasket	: EPDM
Wedge Nut	: Copper Alloy, Bronze CW 453K	Stem Bearing	: Polyamide Polymer
Bolt & Nuts	: Stainless Steel A4	Coating	: Fusion Bonded Epoxy 300 μm

EPDM Rubber available with NSF 61 approval suitable for potable water.  
Please check with us for other material combinations.

# DIMENSIONS AND PART LIST – RS Gate Valve Series 324

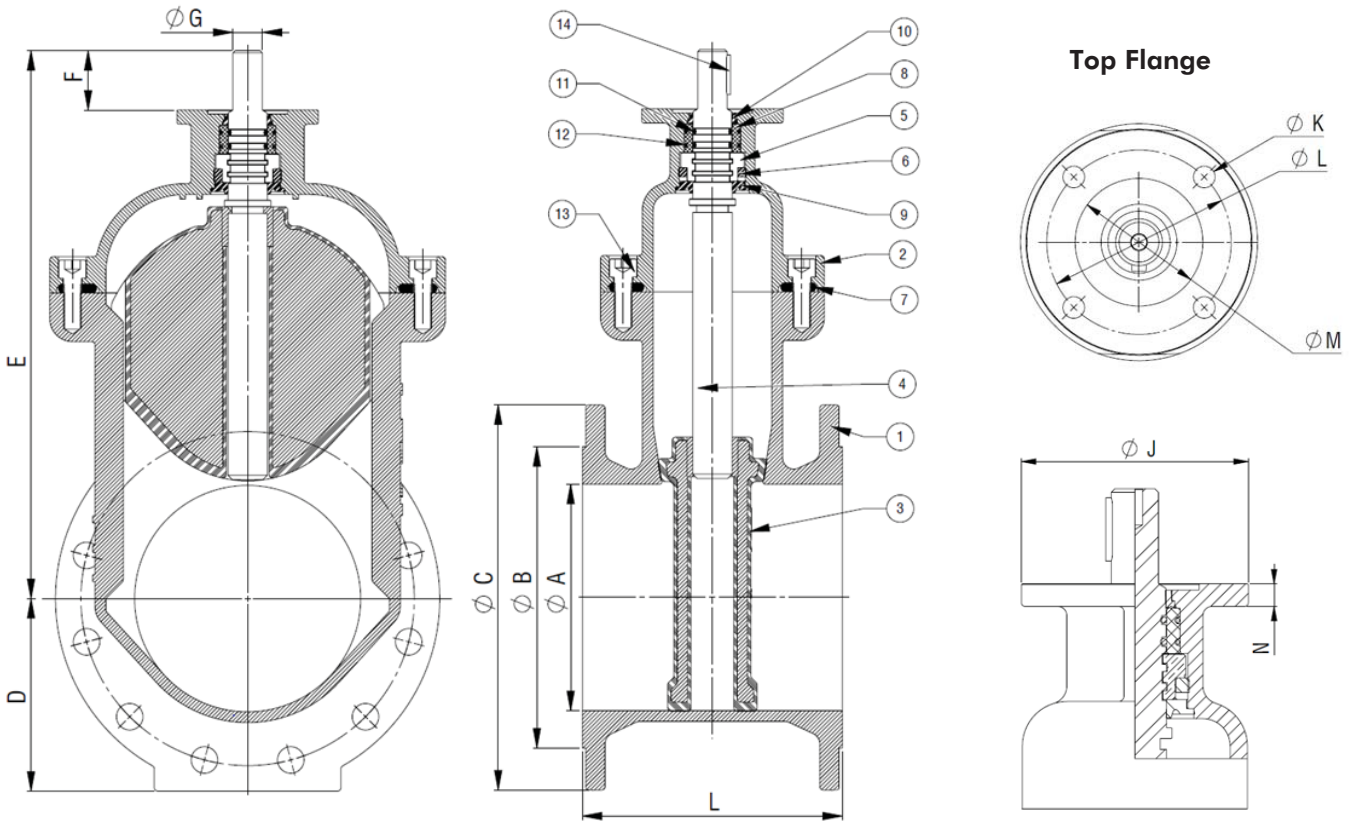

## COMPONENTS

- |           |                      |                 |  |
|-----------|----------------------|-----------------|--|
| 1. Body   | 5. Thrust Collar     | 9. Seal         | 13. Bonnet Bolt  |
| 2. Bonnet | 6. Thrust Collar Nut | 10. End Seal    | Flange "N" Nos thru holes of dia "H"<br>equally spaced on PCD of "P" |
| 3. Wedge  | 7. Gasket            | 11. O Ring Stem |  |
| 4. Stem   | 8. Bush              | 12. O Ring Bush |  |

## DIMENSIONS (mm) for PN 16

Size DN	L	ØA	ØB	ØC	D	E	F	ØG	Flange			Weight (Kg.)
									H	N Nos	P PCD	
50	150	50	99	165	82.5	233	45.5	18.5	19	4	125	12.5
80	180	80	132	200	100	267.3	46.3	21.5	19	8	160	17.5
100	190	100	156	220	110	304	46	25.4	19	8	180	23
150	210	150	211	285	142.5	404	50.5	26	23	8	240	41
200	230	200	266	340	170	484	52.5	26	23	12	295	61
250	250	250	319	400	200	575	65	32	28	12	355	88
300	270	300	370	455	227.5	695	65	32	28	12	410	153

## DIMENSIONS (mm) for Top Flange

Size DN	ISO 5210 Flange	ØJ	ØK	ØL PCD	Ø M (Min)	N	KEY
50	F10	125	12	102	70	12	6x6x35L
80	F10	125	12	102	70	13	6x6x35L
100	F10	125	12	102	70	13	8x7x35L
150	F10	125	12	102	70	13	8x7x35L
200	F10	125	12	102	70	13	8x7x35L
250	F14	205	18	140	100	23	8x7x35L
300	F14	205	18	140	100	23	8x7x35L



Kennedy and McWane Gulf are divisions of McWane Inc. USA  
The specifications and material grades shown are subject to revision without notice based on our product improvement programme