



# Kennedy Valve

## Returning Home with THE KENNEDY K81V VINTAGE HYDRANT



- The 5¼ Main Valve Opening Kennedy Vintage Hydrant is a modernized replica of the original Kennedy “Cage” Hydrant.
- Shares all the same components as the current K81D Guardian Fire Hydrant. Existing Guardian Hydrants can be retrofitted with Vintage Upper and Bonnet Castings.
- Vintage Hydrants are manufactured with standard Guardian K-81D internal parts: no need for special tools. The Vintage hydrant can be maintained with parts and kits already in your inventory.
- Durable Heat Fused Polyester Coating. Red Upper and White Caps as a standard. Color variations available.
- Nostalgic look. Great for locations where you want your hydrants to have Pizzazz!

***Sometimes things are better left alone. If you long for the nostalgic style of past eras with modernized functionality, the VINTAGE hydrant is just what you are looking for.***



# AWWA VINTAGE HYDRANT Kennedy Valve

Division of McWane, Inc.

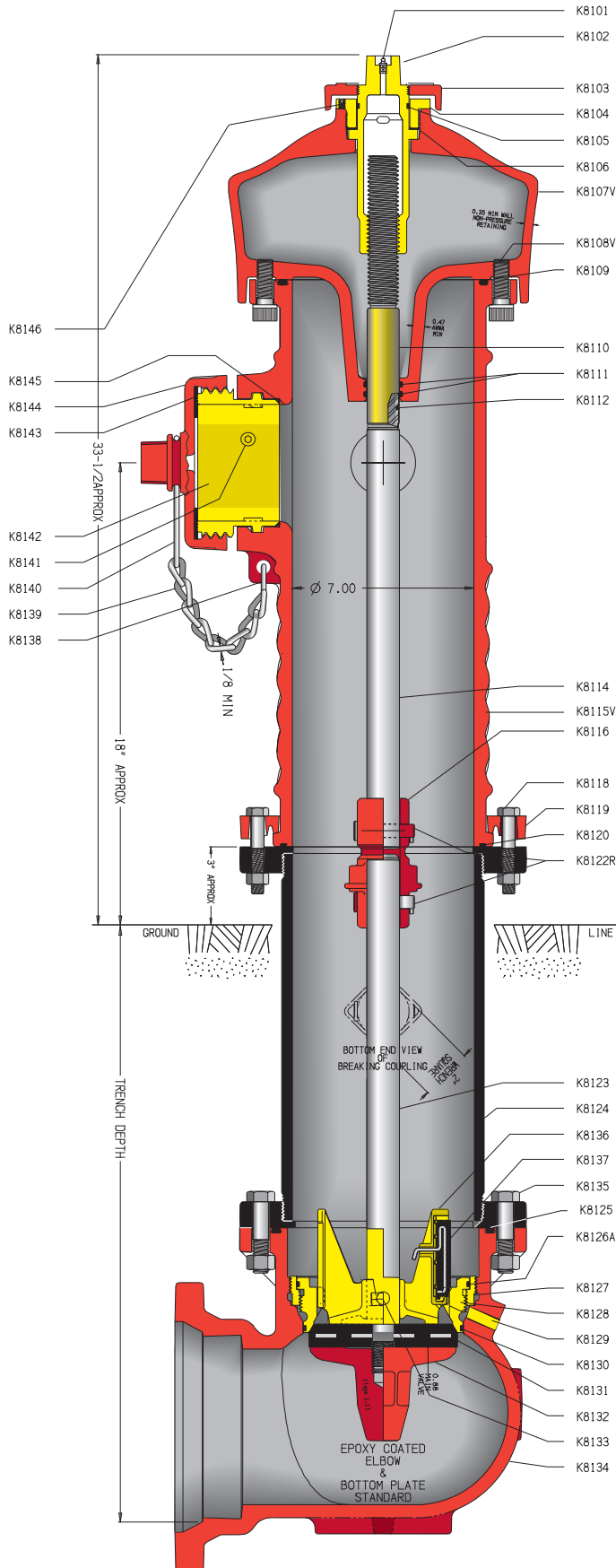

MECHANICAL JOINT CONNECTION SHOWN.  
FLANGED & PUSH ON ALSO AVAILABLE.  
IN GRAY IRON, ASTM A126 CLASS B MAT'L.  
(6" TYPICAL, 4" TECH. JOINT  
AVAILABLE ON ORDER)

5 1/4" MVO  
Drain holes are shown rotated 90° for clarity.  
Updated 02/14/12

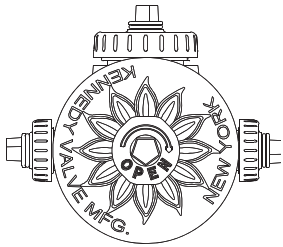

### ACCESSORIES ORDER BY HYDRANT SIZE

EXTENSION  
KIT K8150

SEAT  
REMOVING  
WRENCH K8147

NOZZLE REMOVING  
TOOLS K8148  
ORDER BY NOZZLE I.D.

COLLISION  
REPAIR KIT  
K8149

REQUIRED NUTS, BOLTS & GASKETS INCLUDED WITH KIT

## P A R T S L I S T

DETAIL	PART	MATERIAL	ASTM SPEC (or as stated)
K8101	ALEMITE FITTING	STAINLESS STEEL	A276 (304)
†	K8102 OPERATING STEM NUT	BRONZE	B584 C836/844 -MIN YS 14KSI
	K8103 DIRT SHIELD	CAST IRON	A126 CLASS B
	K8104 STEM LOCK NUT	BRONZE	B584 C836/844 -MIN YS 14KSI
†	K8105 O-RING	BUNA-N (SYN. RUBBER)	D2000
†	K8106 THRUST WASHER	NYLATRON GS	MIL LP-410
	K8107V HYDRANT CAP	CAST IRON	A126 CLASS B
s	K8108V SOCKET HEAD CAP SCREWS	STEEL-302/304 Stainless	F593C
†	K8109 CAP SEAL	RUBBER	D2000
*	K8110 STEM FERRULE	BRASS	B135 C26000
†	K8111 O-RING	BUNA-N (SYN. RUBBER)	D2000
*	K8112 O-RING	BUNA-N (SYN. RUBBER)	D2000
	K8114 UPPER STEM	COLD DRAWN STEEL	A108 C1018
	K8115V UPPER BARREL	CAST IRON	A126 CLASS B
	K8116 STEM BREAKING COUPLING	CAST IRON	A126 CLASS B
s	K8118 BOLTS & NUTS	STEEL-302/304 Stainless	F593C
	K8119 BREAKING RING	CAST IRON	A126 CLASS B
	K8120 O-RING	BUNA-N (SYN. RUBBER)	D2000
	K8122R COUPLING PINS	STAINLESS STEEL	302HQ
	K8123 LOWER STEM	COLD DRAWN STEEL	A 108 C1018
	K8124 LOWER BARREL	DUCTILE IRON	ANSI/AWWA C151/A21.51
†	K8125 ELBOW SEAL	RUBBER	D2000
†	K8126A O-RING	BUNA-N (SYN. RUBBER)	D2000
*	K8127 SEAT RING INSERT	BRONZE	B584 C836/844 -MIN YS 14KSI
†	K8128 SEAT RING	BRONZE	B584 C83600
	K8129 DRAIN TUBE	BRASS	B135 C33000
†	K8130 O-RING	BUNA-N (SYN. RUBBER)	D2000
†	K8131 MAIN VALVE	SBR w/ STEEL INSERT	D2000
	K8132 BOTTOM PLATE	CAST IRON	A126 CLASS B
	K8133 DRAIN VALVE PIN	STAINLESS STEEL	410/416
	K8134 ELBOW	DUCTILE IRON	A536 GRADE 70-50-5
s	K8135 ELBOW BOLTS AND NUTS	304 STAINLESS STEEL	F593C
†	K8136 DRAIN VALVE	ALUMINUM BRONZE	B806 C95400/C95500
	K8137 DRAIN VALVE FACING w/INSERT	BUNA-N w/STAINLESS STEEL	D2000/A276 (304)
	K8138 NOZZLE CHAIN 'S' HOOK	ZINC PLATED STEEL	A108
*	K8139 NOZZLE CAP CHAIN	ZINC PLATED STEEL	A108
*	K8140 NOZZLE CAP BAND	ZINC PLATED STEEL	A108
†	K8141 NOZZLE RETAINING SCREW	STAINLESS STEEL	A276 (304)
#	K8142 NOZZLE	BRONZE	B584 C83600
#	K8143 NOZZLE CAP GASKET	NEOPREME	D 2000
#	K8144 NOZZLE CAP	CAST IRON	A126 CLASS B
† #	K8145 O-RING	BUNA-N (SYN. RUBBER)	D2000
	K8146 ALLEN HEAD SET SCREW	STAINLESS STEEL	A276 (410)
†	K8147 SEAT REMOVAL WRENCH		
	K8148 NOZZLE REMOVAL TOOLS		
†	K8149 COLLISION REPAIR KIT		
	K8150 GRADE EXTENSION KIT		

\* Denotes that part is available only as part of an assembly.  
 # Must specify type of Nozzle, Hose or Steamer.  
 † Recommended spare parts.

MARKING

20 10

CURRENT YEAR



OPEN DIRECTION  
ON DIRT SHIELD



The VINTAGE Hydrant meets or exceeds all requirements of AWWA C-502.



# Kennedy Valve

A DIVISION OF McWANE, INC.

[www.kennedyvalve.com](http://www.kennedyvalve.com)

2009

1021 E. Water Street • Elmira, New York 14901

P.O. Box 981

PHONE: (607) 734-2211 • FAX: 1-800-952-4771