

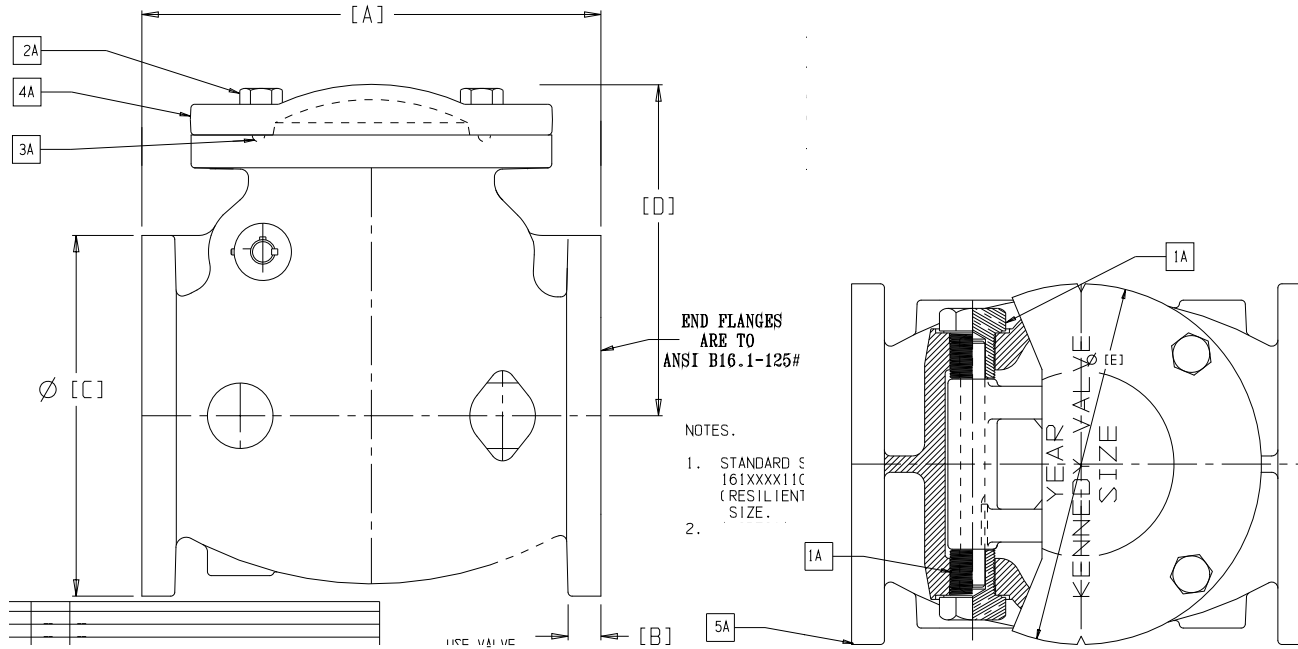

KENNEDY VALVE

# FIG. 1106 / 1106A - AWWA STANDARD CHECK VALVE FULL WALL / DOMESTIC



DIMENSIONS						
	DA LG	FLG THK	FLG DD	DA HT	COVER DD	WALL THK
Size	A	B	C	D	E	J
2"	8"	0.66"	6"	6"	6"	0.34"
2.5"	8.5"	0.72"	7"	6.44"	7"	0.41"
3"	9.5"	0.78"	7.5"	6.85"	7.5"	0.44"
4"	11.5"	1.00"	9"	8.69"	9"	0.50"
6"	14"	1.06"	11"	10.51"	11"	0.62"
8"	19.5"	1.25"	13.5"	12.56"	13.5"	0.75"
10"	24.5"	1.31"	16"	14.07"	16.75"	0.81"
12"	27.5"	1.38"	19"	16.13"	19"	0.88"

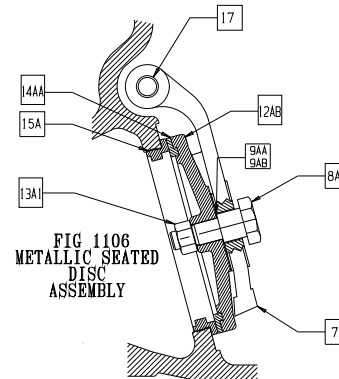
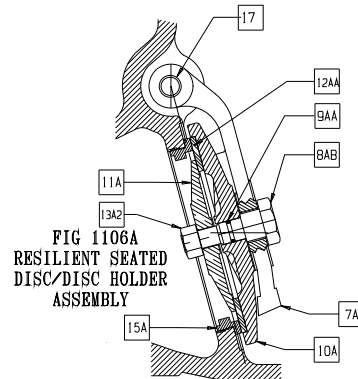

COVER / BODY ATTACHMENTS			
No.	QTY.	Description	Material
1A	2	Side Plug	Bronze B371 C69300
2A	A/R	Hex Bolt	Stainless Steel 18-8
3A	1	O-Ring Seal Cover to Body	Buna-N
4A	1	Check Valve Cap	Gray, Cast Iron ASTM A 126B
5A	1	Body	Gray, Cast Iron ASTM A 126B
7A	1	Hinge	Bronze (2"-3") / Ductile Iron (4"-12")
8AA	1	Disc Bolt (Metal to Metal)	Bronze (10" & 12")
8AA	1	Disc Bolt (Metal to Metal)	Steel (4"-12") (N/A 2"-3", Integral w/ Disc)
8AB	1	Disc Bolt (Resilient)	Bronze (4"-12") (N/A 2"-3", Integral w/ Disc)
9AA	2	Disc Bolt O-Ring, Fig. 1106	Buna-N (10" & 12")
9AA	2	Disc Bolt, Fig. 1106A	Buna-N (4"-12") (N/A 2"-3")
9AB	2	Disc Bolt Gasket	Fibre (4"-8")
10A	1	Disc Holder	Gray, Cast Iron (4"-12", ex. 8")
10A	1	Disc Holder	Ductile Iron (8")
10A	1	Disc Holder w/ Integral Bolt	Bronze (2"-3")
11A	1	Disc Plate	Stainless Steel (2"-3"), Bronze (4"-12")
12AA	1	Replacable Rubber Disc	Rubber
12AB	1	Disc w/ Integral Bronze Ring	Gray Cast Iron (4"-12")
12AB	1	Disc w/ Integral Bolt & Ring	Bronze (2" - 3")
13A1	1	Hex Nut - Disc	SS18-8 (2-12") Metal to Metal
13A2	1	Hex Nut - Disc Holder	SS18-8, 2 Nuts (2"-3")
14AA	1	Disc Ring - Integral w/ Disc	Solid Bronze Disc (2"-3"), Bronze (4"-12")
15A	1	Seat Ring	Bronze ASTM B584 C89833 / C87850
17	1	Hinge Pin	Stainless Steel A-276 (304)

**NOTES:**

- Standard syntax for a standard check valve is: 161XXXX1106 (Brass to Brass) or 161XXXX1106A (Resilient to Brass), where "XXXX" signifies the size.
- A special "Buy America" valve can be obtained by specifying "DOM" after the standard number.
- Use valve flow horizontal or vertical with flow up.



KENNEDY VALVE

# FIG. 1106LS / 1106AS - AWWA CHECK VALVE FULL WALL / DOMESTIC with LEVER & SPRING (SPRING ONE-SIDE)

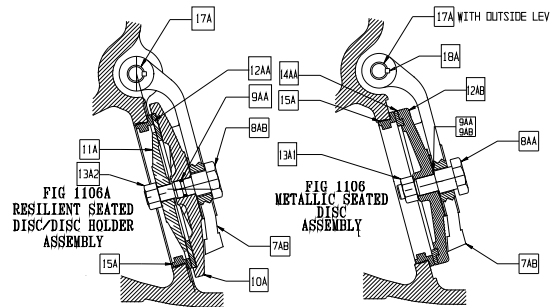
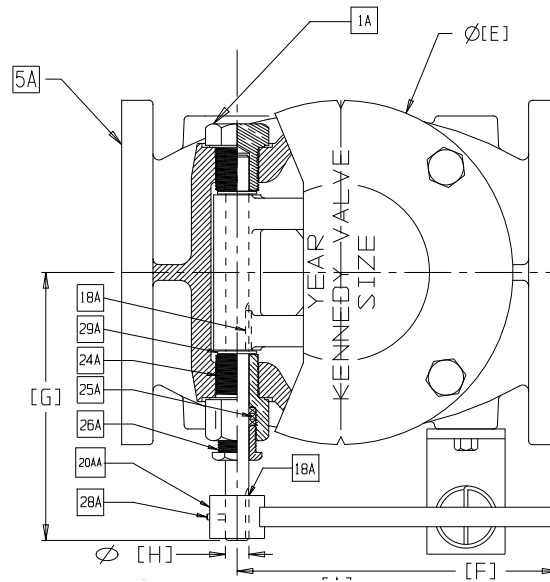
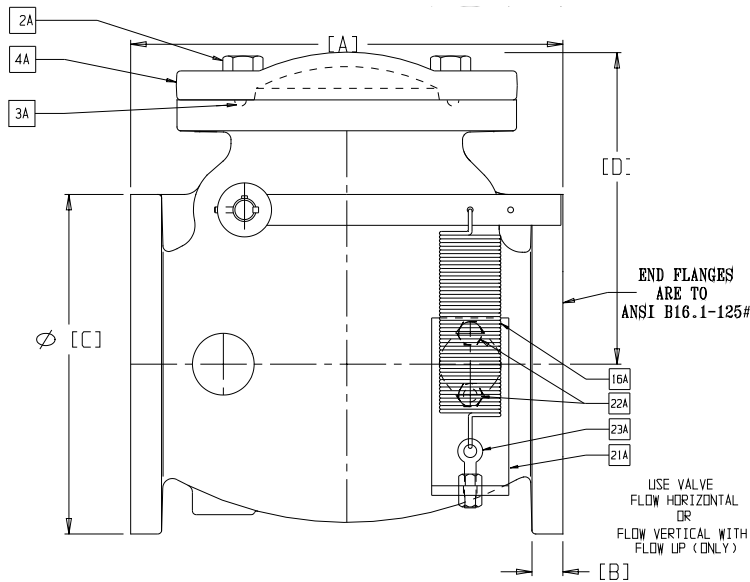

DIMENSIONS									
	DA LG	FLG THK	FLG DD	DA HT	COVER DD	LEVER LG	CL to PIN END	PIN DIA	WALL THK
Size	A	B	C	D	E	F	G	H	J
2"	8"	0.66"	6"	6"	6"	6"	4.72"	0.50"	0.34"
2.5"	8.5"	0.72"	7"	6.44"	7"	6"	4.94"	0.50"	0.41"
3"	9.5"	0.78"	7.5"	6.85"	7.5"	6"	5.35"	0.50"	0.44"
4"	11.5"	1.00"	9"	8.69"	9"	7.75"	8.19"	0.63"	0.50"
6"	14"	1.06"	11"	10.51"	11"	9.75"	9"	0.75"	0.62"
8"	19.5"	1.25"	13.5"	12.56"	13.5"	14.13"	10.19"	0.88"	0.75"
10"	24.5"	1.31"	16"	14.07"	16.75"	18"	11.63"	1.00"	0.81"
12"	27.5"	1.38"	19"	16.13"	19"	18"	13.75"	1.00"	0.88"

COVER / BODY ATTACHMENTS			
No.	QTY.	Description	Material
1A	1	Side Plug	Bronze B371
2A	A/R	Hex Bolt	Stainless Steel ASTM A276
3A	1	O-Ring Seal Cover to Body	Buna-N
4A	1	Check Valve Cap	Gray, Cast Iron ASTM 126B
5A	1	Body	Gray, Cast Iron ASTM 126B
7AB	1	Keyed Hinge (with Lever)	Bronze (2"-3") / Ductile Iron (4"-12") with Lever
8AA	1	Disc Bolt (Metal to Metal)	Bronze (10" & 12")
8AA	1	Disc Bolt (Metal to Metal)	Steel (4"-12") (N/A 2"-3", Integral w/ Disc)
8AB	1	Disc Bolt (Resilient)	Bronze (4"-12") (N/A 2"-3", Integral w/ Disc)
9AA	1	Disc Bolt O-Ring, Fig. 1106	Buna-N (10" & 12")
9AA	1	Disc Bolt, Fig. 1106A	Buna-N (4"-12") (N/A 2"-3")
9AB	2	Disc Bolt Gasket, Fig. 1106	Fibre (4"-8")
10A	1	Disc Holder	Gray, Cast Iron (4"-12", ex. 8")
10A	1	Disc Holder	Ductile Iron (8")
11A	1	Disc Plate	Bronze
12AA	1	Replacable Rubber Disc	Rubber
12AB	1	Disc w/ Integral Bronze Ring	Gray Cast Iron (4"-12")
12AB	1	Disc w/ Integral Bolt & Ring	Bronze (2.5" - 3")
13A1	1	Hex Nut - Disc	SS18-8 (2-12") Metal to Metal
13A2	1	Hex Nut - Disc Holder	SS18-8, 2 Nuts (2"-3")
14AA	1	Disc Ring - Integral w/ Disc	Bronze (4"-12")
14AA	1	Disc Ring - Integral w/ Disc	Solid Bronze Disc (2"-3")
15A	1	Seat Ring	Bronze ASTM B584 C89833 / C87850
16A	1	Spring (for L/S)	Steel
17A	1	Extended Hinge Pin (for Lever)	Stainless Steel A-276 (304)
18A	2	Key	Stainless Steel 16-6 (302 / 304)
20AA	1	Lever Arm (for L/S)	Steel
21A	1	Bracket (for D/S)	Steel
22A	2	Hex Head Bolt (L/S Bracket)	Steel
23A	1	Eye Bolt w/ 2 Hex Nuts	Steel
24A	1	Side Plug Stuffing Box	Bronze ASTM B371 C69300
25A	A/R	Packing	NON Asbestos
26A	1	Gland	Bronze ASTM B371 C69300
28A	1	Lever Set Screw	Steel
29A	2	Washers	Stainless Steel



KENNEDY VALVE

# FIG. 1106LW / 1106AW - AWWA CHECK VALVE FULL WALL / DOMESTIC with LEVER & WEIGHT (WEIGHT ONE-SIDE) HORIZONTAL

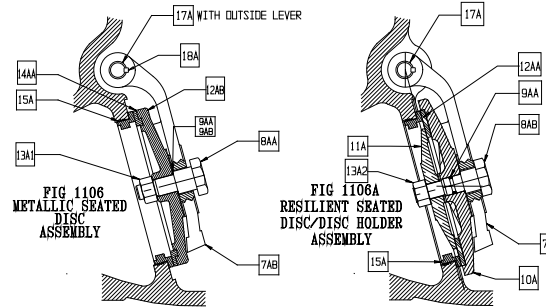
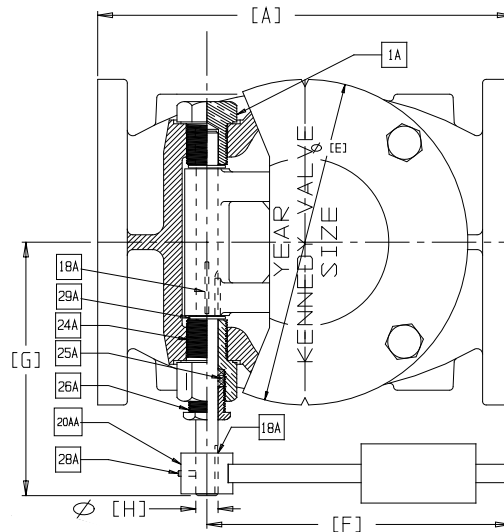
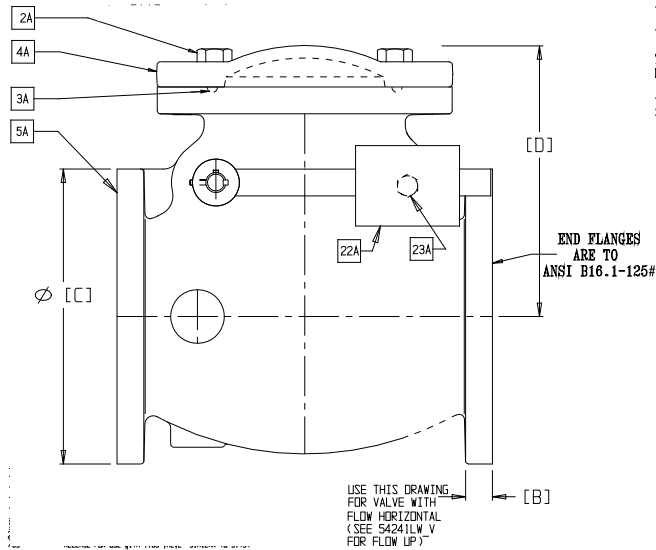

DIMENSIONS									
	DA LG	FLG THK	FLG DD	DA HT	COVER DD	LEVER LG	CL to PIN END	PIN DIA	WALL THK
Size	A	B	C	D	E	F	G	H	J
2"	8"	0.66"	6"	6"	6"	6"	4.72"	0.50"	0.34"
2.5"	8.5"	0.72"	7"	6.44"	7"	6"	4.94"	0.50"	0.41"
3"	9.5"	0.78"	7.5"	6.85"	7.5"	6"	5.35"	0.50"	0.44"
4"	11.5"	1.00"	9"	8.69"	9"	7.75"	8.19"	0.63"	0.50"
6"	14"	1.06"	11"	10.51"	11"	9.75"	9"	0.75"	0.62"
8"	19.5"	1.25"	13.5"	12.56"	13.5"	14.13"	10.19"	0.88"	0.75"
10"	24.5"	1.31"	16"	14.07"	16.75"	18"	11.63"	1.00"	0.81"
12"	27.5"	1.38"	19"	16.13"	19"	18"	13.75"	1.00"	0.88"

COVER / BODY ATTACHMENTS			
No.	QTY.	Description	Material
1A	1	Side Plug	Bronze B371
2A	A/R	Hex Bolt	Stainless Steel 18-8
3A	1	O-Ring Seal Cover to Body	Buna-N
4A	1	Check Valve Cap	Gray, Cast Iron ASTM 126B
5A	1	Body	Gray, Cast Iron ASTM 126B
7AB	1	Keyed Hinge (with Lever(s))	Bronze (2"-3") / Ductile Iron (4"-12") with Lever
8AA	1	Disc Bolt (Metal to Metal)	Bronze (10" & 12")
8AA	1	Disc Bolt (Metal to Metal)	Steel (4"-12") (N/A 2"-3", Integral w/ Disc)
8AB	1	Disc Bolt (Resilient)	Bronze (4"-12") (N/A 2"-3", Integral w/ Disc)
9AA	2	Disc Bolt O-Ring, Fig. 1106	Buna-N (10" & 12")
9AA	2	Disc Bolt, Fig. 1106A	Buna-N (4"-12") (N/A 2"-3")
9AB	2	Disc Bolt Gasket	Fibre (4"-8")
10A	1	Disc Holder	Gray, Cast Iron (4"-12", ex. 8")
10A	1	Disc Holder	Ductile Iron (8")
10A	1	Disc Holder w/ Integral Bolt	Bronze (2"-3")
11A	1	Disc Plate	Stainless Steel (2"-3"), Bronze (4"-12")
12AA	1	Replaceable Rubber Disc	Rubber
12AB	1	Disc w/ Integral Bronze Ring	Gray Cast Iron (4"-12")
12AB	1	Disc w/ Integral Bolt & Ring	Bronze (2.5" - 3")
13A1	1	Hex Nut - Disc	SS18-8 (2-12") Metal to Metal
13A2	1	Hex Nut - Disc Holder	SS18-8, 2 Nuts (2"-3")
14AA	1	Disc Ring - Integral w/ Disc	Solid Bronze Disc (2"-3"), Bronze (4"-12")
15A	1	Seat Ring	Bronze ASTM B584 C89833 / C87850
17A	1	Extended Hinge Pin (for Lever)	Stainless Steel A-276 (304)
18A	2	Key	Stainless Steel 16-6 (302 / 304)
22A	1	Set Screw for Weight	Steel, Plated A307
23A	1	Weight	Gray, Iron A126B
24A	1	Side Plug Stuffing Box	Bronze ASTM B371 C69300
25A	A/R	Packing	NON Asbestos
26A	1	Gland	Bronze ASTM B371 C69300
28A	1	Lever Set Screw	Steel
29A	2	Washers	Stainless Steel



KENNEDY VALVE

# FIG. 1106LW / 1106AW - AWWA CHECK VALVE FULL WALL / DOMESTIC with LEVER & WEIGHT (WEIGHT ONE-SIDE) VERTICAL

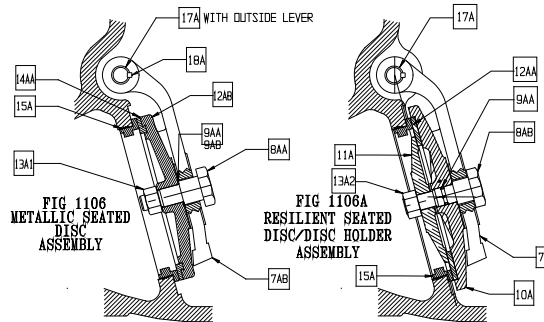
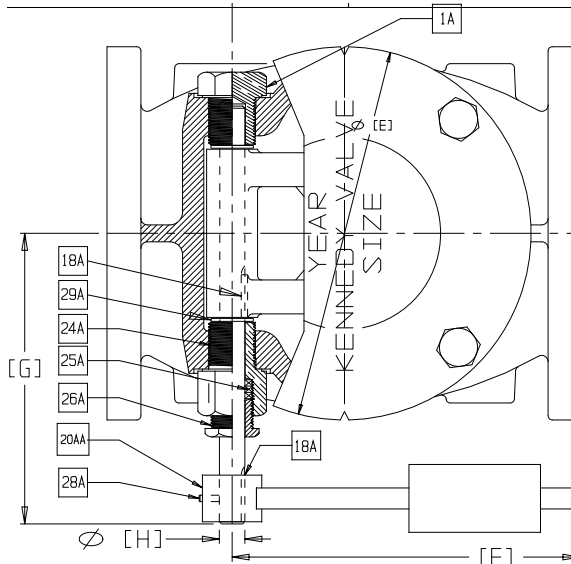
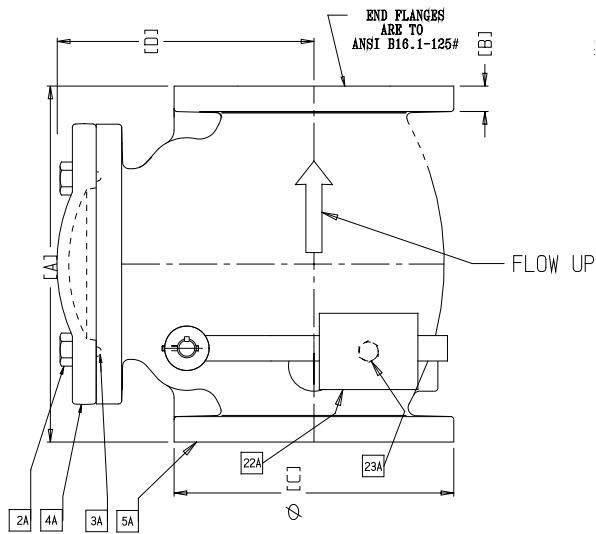

DIMENSIONS									
	DA LG	FLG THK	FLG DD	DA HT	COVER DD	LEVER LG	CL to PIN END	PIN DIA	WALL THK
Size	A	B	C	D	E	F	G	H	J
2"	8"	0.66"	6"	6"	6"	6"	4.72"	0.50"	0.34"
2.5"	8.5"	0.72"	7"	6.44"	7"	6"	4.94"	0.50"	0.41"
3"	9.5"	0.78"	7.5"	6.85"	7.5"	6"	5.35"	0.50"	0.44"
4"	11.5"	1.00"	9"	8.69"	9"	7.75"	8.19"	0.63"	0.50"
6"	14"	1.06"	11"	10.51"	11"	9.75"	9"	0.75"	0.62"
8"	19.5"	1.25"	13.5"	12.56"	13.5"	14.13"	10.19"	0.88"	0.75"
10"	24.5"	1.31"	16"	14.07"	16.75"	18"	11.63"	1.00"	0.81"
12"	27.5"	1.38"	19"	16.13"	19"	18"	13.75"	1.00"	0.88"

COVER / BODY ATTACHMENTS			
No.	QTY.	Description	Material
1A	1	Side Plug	Bronze B371 C69300
2A	A/R	Hex Bolt	Stainless Steel 18-8
3A	1	O-Ring Seal Cover to Body	Buna-N
4A	1	Check Valve Cover	Gray, Cast Iron ASTM A 126B
5A	1	Body	Gray, Cast Iron ASTM A 126B
7AB	1	Keyed Hinge (with Lever(s))	Bronze (2"-3") / Ductile Iron (4"-12") with Lever
8AA	1	Disc Bolt (Metal to Metal)	Bronze (10" & 12")
8AA	1	Disc Bolt (Metal to Metal)	Steel (4"-12") (N/A 2"-3", Integral w/ Disc)
8AB	1	Disc Bolt (Resilient)	Bronze (4"-12") (N/A 2"-3", Integral w/ Disc)
9AA	2	Disc Bolt O-Ring, Fig. 1106	Buna-N (10" & 12")
9AA	2	Disc Bolt, Fig. 1106A	Buna-N (4"-12") (N/A 2"-3")
9AB	2	Disc Bolt Gasket	Fibre (4"-8")
10A	1	Disc Holder	Gray, Cast Iron (4"-12", ex. 8")
10A	1	Disc Holder	Ductile Iron (8")
10A	1	Disc Holder w/ Integral Bolt	Bronze (2"-3")
11A	1	Disc Plate	Stainless Steel (2"-3"), Bronze (4"-12")
12AA	1	Replaceable Rubber Disc	Rubber
12AB	1	Disc w/ Integral Bronze Ring	Gray Cast Iron (4"-12")
12AB	1	Disc w/ Integral Bolt & Ring	Bronze (2" - 3")
13A1	1	Hex Nut - Disc	SS18-8 (2-12") Metal to Metal
13A2	1	Hex Nut - Disc Holder	SS18-8, 2 Nuts (2"-3")
14AA	1	Disc Ring - Integral w/ Disc	Solid Bronze Disc (2"-3"), Bronze (4"-12")
15A	1	Seat Ring	Bronze ASTM B584 C89833 / C87850
17A	1	Extended Hinge Pin (for Lever)	Stainless Steel A-276 (304)
18A	2	Key	Stainless Steel 16-6 (302 / 304)
20AA	1	Lever Arm (for L/S)	Steel
22A	1	Set Screw for Weight	Steel, Plated A307
23A	1	Weight	Gray, Iron A126B
24A	1	Side Plug Stuffing Box	Bronze ASTM B371 C69300
25A	A/R	Packing	NON Asbestos
26A	1	Gland	Bronze ASTM B371 C69300
28A	1	Lever Set Screw	Steel
29A	2	Washers	Stainless Steel

**NOTES:**

1. Use alternate notch in lever for this orientation.