



KENNEDY VALVE

C509 KS FW NON-RISING RESILIENT SEATED GATE VALVE CUTTING-IN ENDS SIZES 4"- 12"

Fig. 8576SS

Fig. 8576PSS (with post plate)

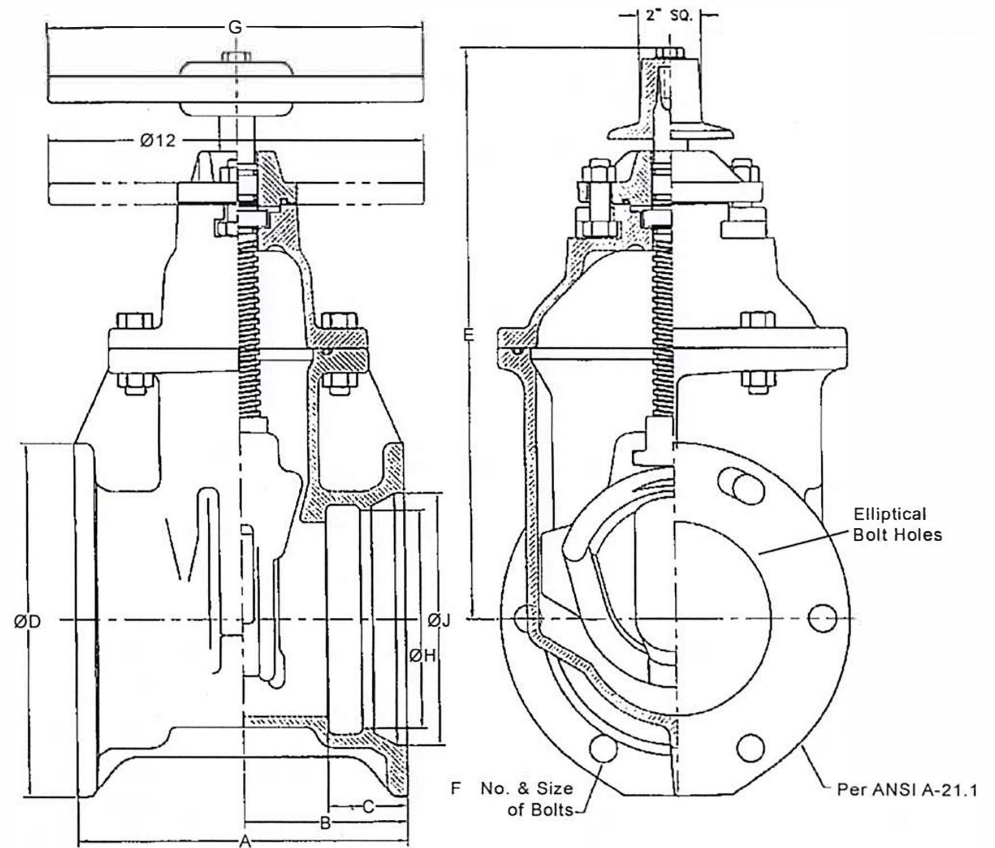

Elliptical bolt hole design eliminates the needs for anti-rotational bolts.

DIMENSIONS										
SIZE	A	B	C	D	E	F	G	H	J	Weight (lbs.)
4	9-1/2"	4-3/4"	2-1/2"	9-1/8"	14-3/4"	4-3/4"	10"	5.10	6.20	86
6	10-1/2"	5-1/4"	2-1/2"	11-3/8"	19"	6-3/4"	12"	7.20	8.30	134
8	13-1/8"	6-9/16"	2-1/2"	13-3/4"	22-1/2"	6-3/4"	14"	9.40	10.50	206
10	15-1/2"	7-3/4"	2-1/2"	15-3/4"	26-1/2"	8-3/4"	18"	11.50	12.62	351
12	16"	8"	2-5/8"	18"	30"	8-3/4"	18"	13.60	14.72	473

Note: Add 16 lbs. for Indicator Post Plate