

Complies with applicable requirements of AWWA C515

**14"-16" R/W VALVE
MJ TAPPING GENERAL DIMENSION**

KENNEDY VALVE

MODEL KS-RW/2638

7950SS

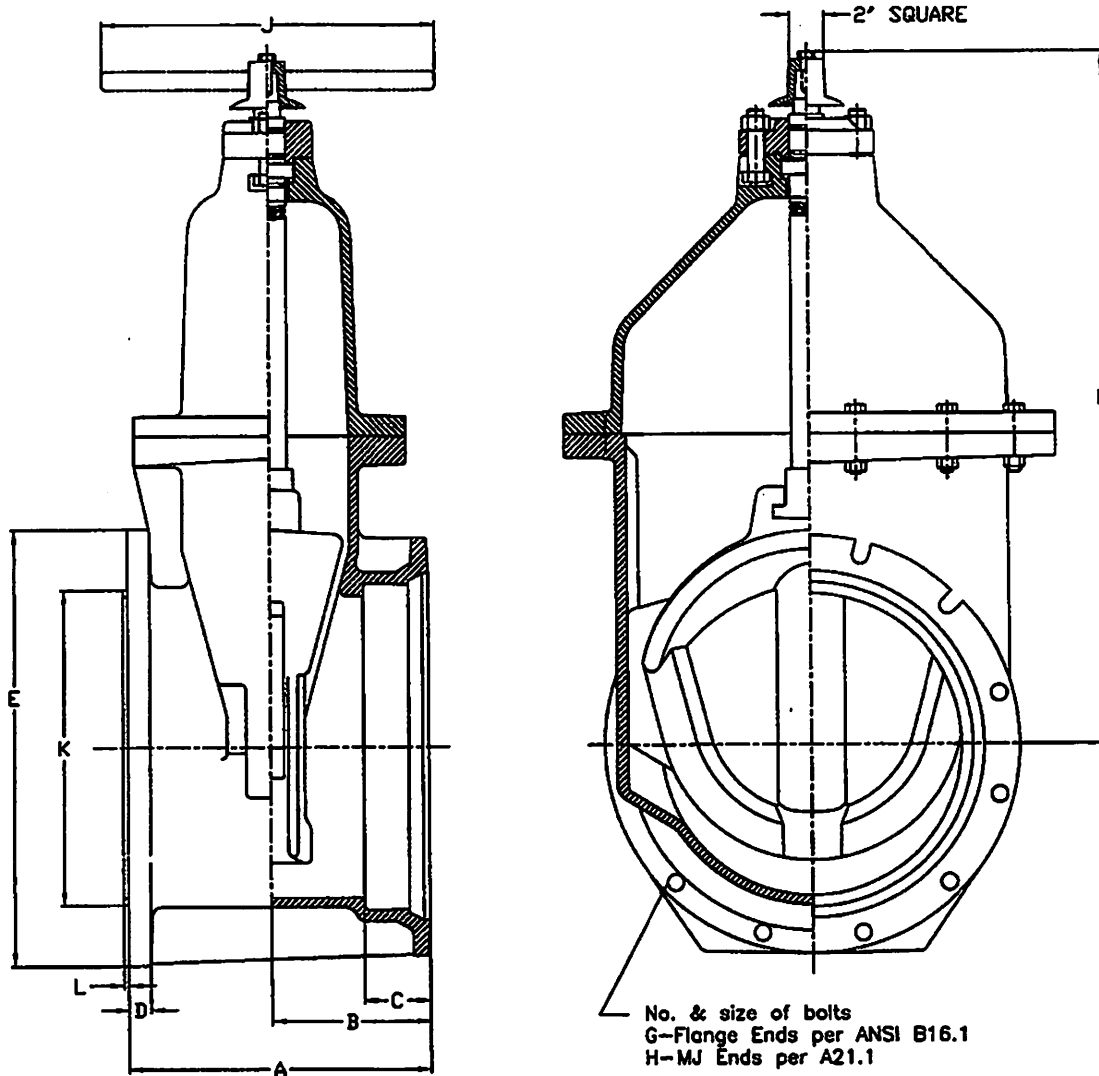

VALVE SIZE	A	B	C	D	E	F	G	H	J	K	L
14	16.75	8.5	3.5	1.18	21	37.75	21-1	10-3/4	18	14 15/16	1/4
16	16.25	8.5	3.5	1.25	23.5	37.75	16-1	12-3/4	18	16 15/16	1/4

Complies
AWWA C515

**14"-24" R/W VALVE MJ TAP END
BEVEL GEAR GENERAL DIMENSIONS**

KENNEDY VALVE

MODEL KS-RW/2638

7950BMSS

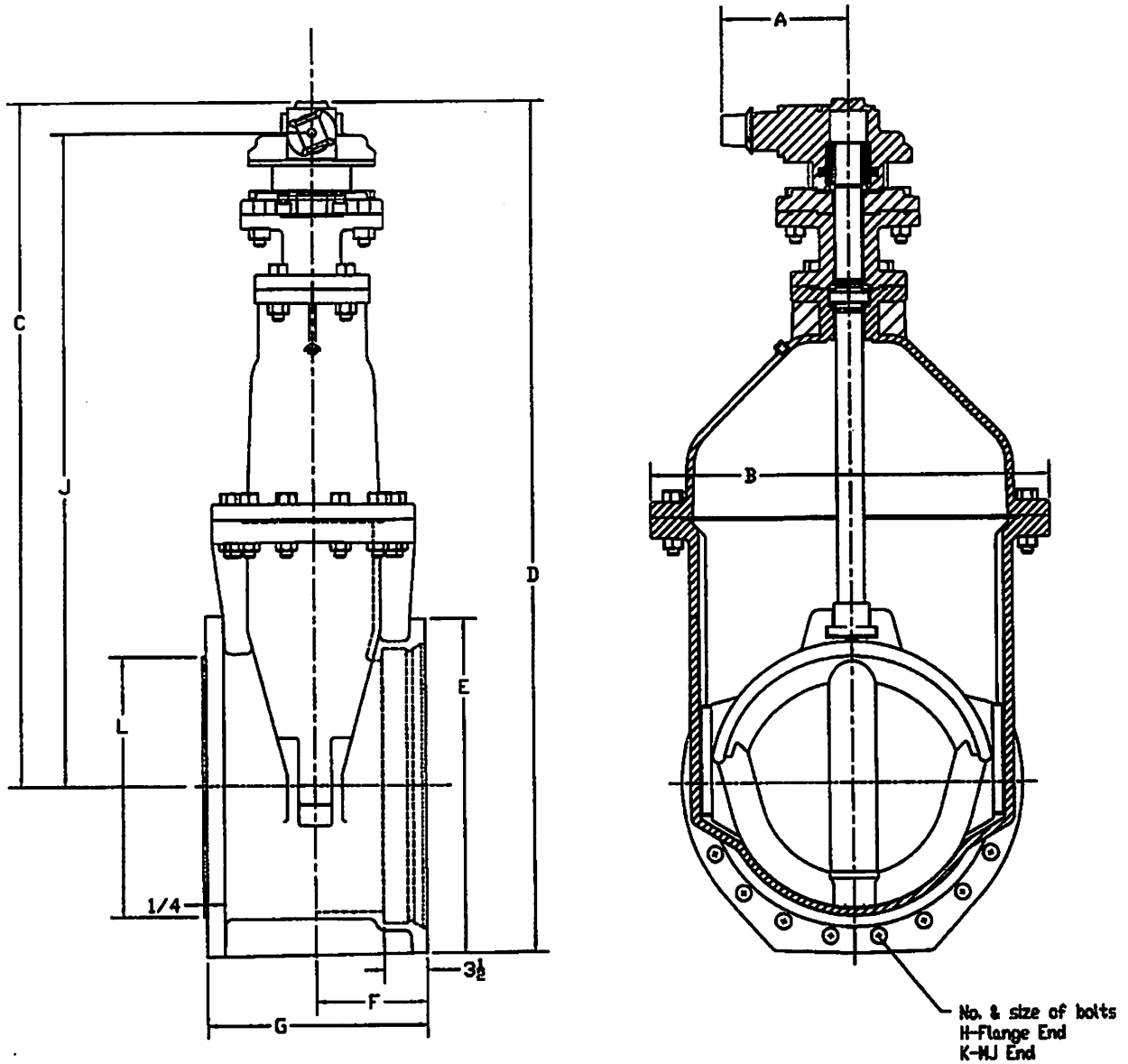

VALVE SIZE	A	B	C	D	E	F	G	H	J	K	L
14	9 1/8	26.69	48 5/8	59 1/2	20 1/4	8 1/2	16 3/4	12-1	46 3/8	10-3/4	14 15/16
16	9 1/8	26.69	47 5/8	59 1/2	22 1/2	8 1/2	17	16-1	45 3/8	12-3/4	16 15/16
18	10 1/8	32 1/4	55 3/4	68 3/4	24 3/4	9 3/8	18 1/8	16-1 1/8	53 3/4	12-3/4	18 15/16
20	10 1/8	32 1/4	54 3/4	68 3/4	27	9	18	20-1 1/8	52 3/4	14-3/4	20 15/16
**24	10 1/8	36 1/2	59 7/8	75 1/8	31 1/2	10 1/2	20 1/2	20-1 1/4	57 3/8	16-3/4	24 15/16

*30" AND LARGER SIZES REQUIRE GEARING
 **24" FURNISHED WITH ROLLERS, TRACKS, AND SCRAPERS.(see
 dimensions on page 6-20 for new installation)

24" R/W RTS BEVEL GEAR MJ X TAP
ENDS GENERAL DIMENSIONS

KENNEDY VALVE

MODEL KS-RW/2638

7950BMSS

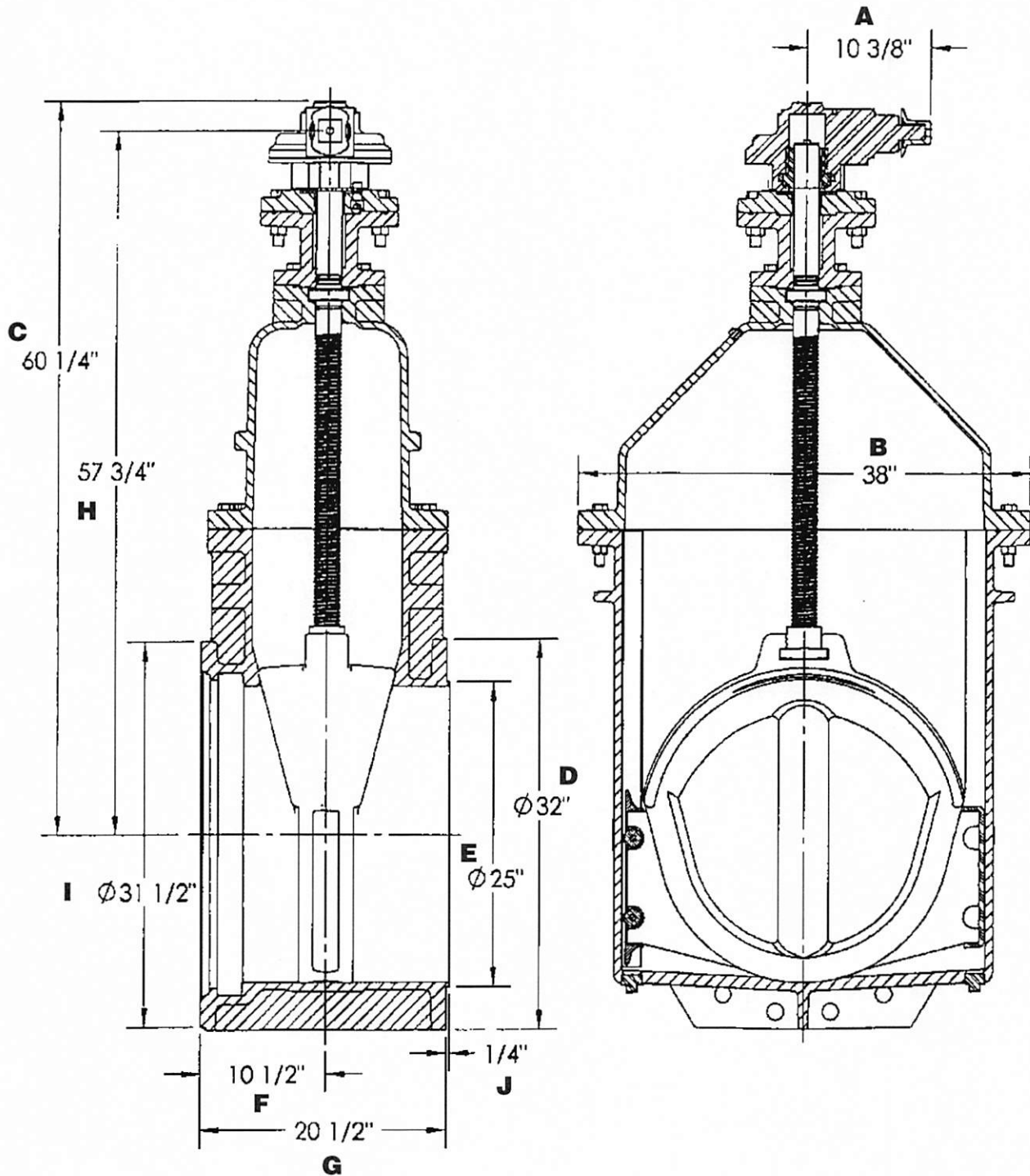

24" R/W RTS BEVEL GEAR MJ X TAP
ENDS GENERAL DIMENSIONS

KENNEDY VALVE

MODEL KS-RW/2638

7950AMSS

