



KENNEDY VALVE

C515 NON-RISING / FIG. 7571AMSS RESILIENT SEATED GATE VALVE MECHANICAL JOINT WITH SPUR GEARING SIZES 14" - 24"

DRAWING NO.- CAT920010A-01 REV - 1

DIMENSIONS								
SIZE	A	B	C	D	E	F	G	H
14	8	26-11/16	52-1/8	62-1/2	20-1/4	8-1/2	17	3/4" x 10
16	8	26-11/16	51-1/8	62-1/2	22-1/2	8-1/2	17	3/4" x 12
18	12	32-1/4	58	70-1/2	24-3/4	9	18	7/8" x 12
20	12	32-1/4	57	70-1/2	27	9	18	7/8" x 14
24	12	38	62-5/8	78-1/4	31-1/4	10-1/2	21	3/4" x 16

30" & larger sizes require gearing.
24" are now furnished with rollers, tracks, and scrapers.

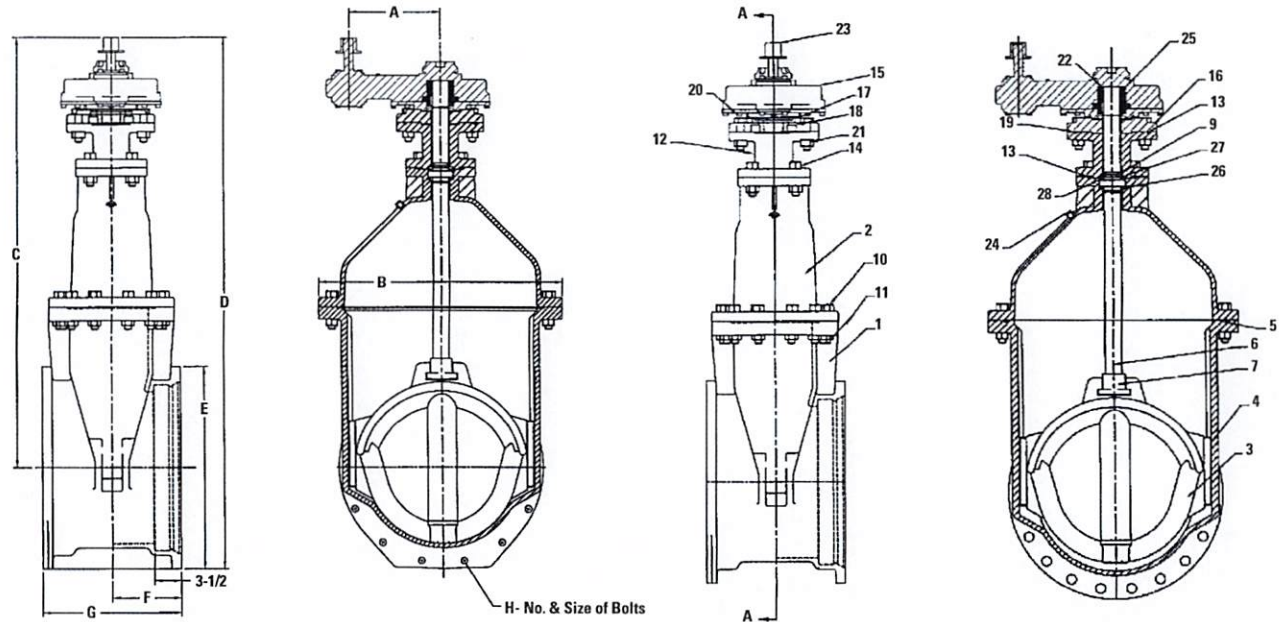

PARTS LIST				PARTS LIST				PARTS LIST			
No.	PART	MATERIAL	ASTM DESIGNATION	No.	PART	MATERIAL	ASTM DESIGNATION	No.	PART	MATERIAL	ASTM DESIGNATION
1	Body	Ductile Iron	ASTM A536 GR 65-45-12	11	Hex Nut	Stainless Steel	ASTM F593-304	20	Hex Bolt	Stainless Steel	ASTM F593-304
2	Cover	Ductile Iron	ASTM A536 GR 65-45-12	12	Extension	Ductile Iron	ASTM A536 65-45-12	21	Hex Nut	Stainless Steel	ASTM F593-304
3	Wedge	Ductile Iron / Rubber EPDM	ASTM A536 GR 65-45-12 / EPDM	13	O-ring	Rubber	NBR	22	Key	Steel	
4	Wedge Cap (18"-24")	Delrin	Delrin	14	Hex Head Bolt	Stainless Steel	ASTM F593-304	23	OP Nut	Ductile Iron	ASTM A536 65-45-12
5	O-ring	Rubber	NBR	15	Actuator - 3:1 (18"-24") 2:1 (14"-16")			24	Pipe Plug	Steel	Steel
6	Stem	Bronze	ASTM B584 C86700	16	Adapter Plate	Ductile Iron	ASTM A536 GR 65-45-12	25	Drive Sleeve	Steel	AISI 1023
7	Stem Nut	Bronze	ASTM B584 C86700	17	Actuator Gasket	Rubber	NBR	26	Cover Bushing	Bronze	ASTM B584 C86700
9	O-ring	Rubber	NBR	18	Socket Head Bolt	Alloy Steel	Alloy Steel	27	Extension Bushing	Bronze	ASTM B584 C86700
10	Hex Head Bolt	Stainless Steel	ASTM F593-304	19	O-ring	Rubber	NBR	28	Thrust Bearing (18"-24")	Delrin	Delrin



KENNEDY VALVE

**C515 NON-RISING / FIG. 7561BMSS
RESILIENT SEATED GATE VALVE
MECHANICAL JOINT
WITH BEVEL GEARING
SIZES 14" - 24"**

DRAWING NO.- CAT920008A-01 REV - 1

DIMENSIONS									
SIZE	A	B	C	D	E	F	G	H	J
14	9-1/8	26-11/16	48-5/8	59	20-1/4	8-1/2	17	3/4" x 10	46-5/8
16	9-1/8	26-11/16	47-5/8	59	22-1/2	8-1/2	17	3/4" x 12	45-5/8
18	10-1/8	32-1/4	55-3/4	68-1/4	24-3/4	9-5/32	18	7/8" x 12	53-3/4
20	10-1/8	32-1/4	54-3/4	68-1/4	27	9-5/32	18	7/8" x 14	52-3/4
24	10-1/8	38	59-7/8	75-1/8	31-1/2	9-1/2	19	3/4" x 16	57-3/8

30" & larger sizes require gearing.
24" are furnished with rollers, tracks, and scrapers.

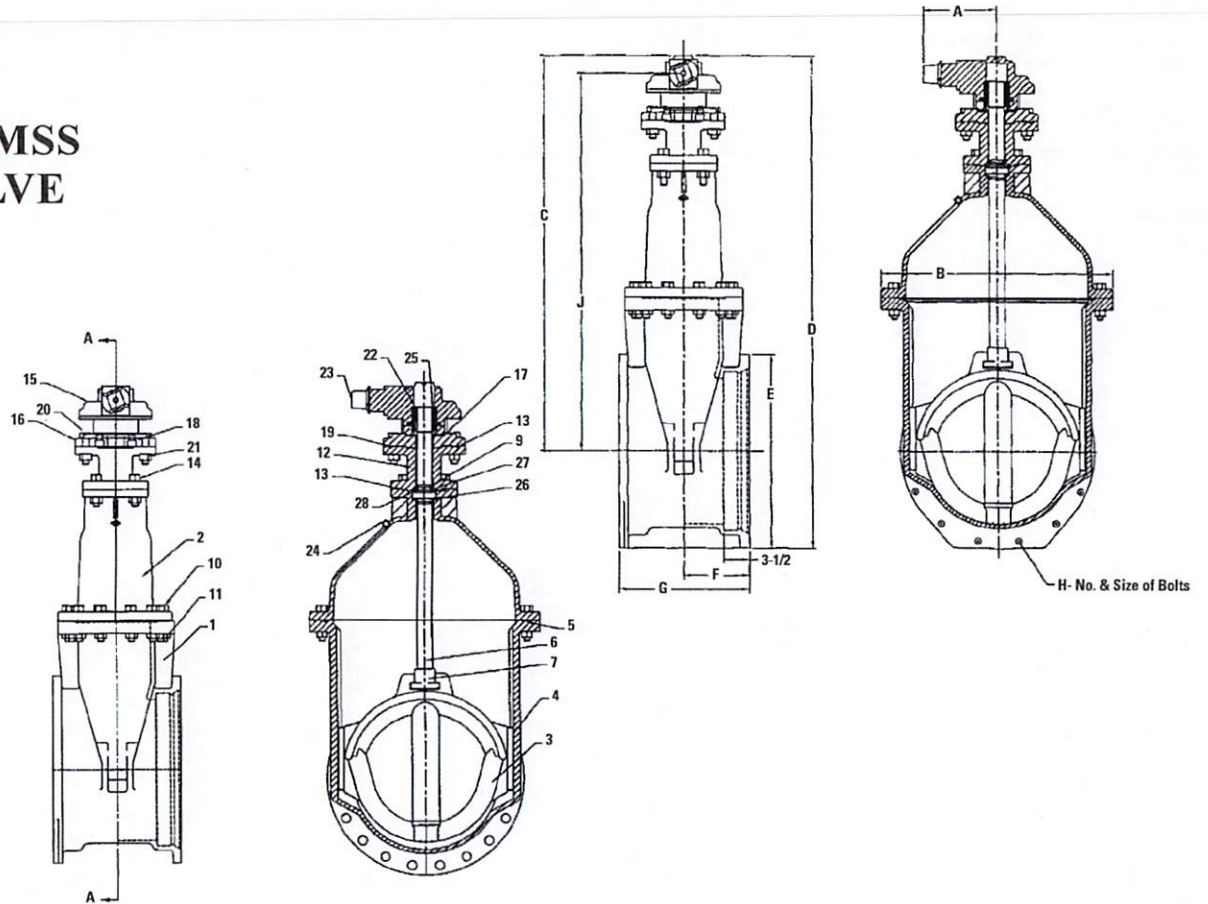

PARTS LIST				PARTS LIST				PARTS LIST			
No.	PART	MATERIAL	ASTM DESIGNATION	No.	PART	MATERIAL	ASTM DESIGNATION	No.	PART	MATERIAL	ASTM DESIGNATION
1	Body	Ductile Iron	ASTM A536 GR 65-45-12	11	Hex Nut	Stainless Steel	ASTM F593-304	20	Hex Bolt	Stainless Steel	ASTM F593-304
2	Cover	Ductile Iron	ASTM A536 GR 65-45-12	12	Extension	Ductile Iron	ASTM A536 65-45-12	21	Hex Nut	Stainless Steel	ASTM F593-304
3	Wedge	Ductile Iron / Rubber EPDM	ASTM A536 GR 65-45-12 / EPDM	13	O-ring	Rubber	NBR	22	Key	Steel	
4	Wedge Cap (18"-24")	Delrin	Delrin	14	Hex Head Bolt	Stainless Steel	ASTM F593-304	23	OP Nut	Ductile Iron	ASTM A536 65-45-12
5	O-ring	Rubber	NBR	15	Actuator - 3:1 (18"-24") 2:1 (14"-16")			24	Pipe Plug	Steel	Steel
6	Stem	Bronze	ASTM B584 C86700	16	Adapter Plate	Ductile Iron	ASTM A536 GR 65-45-12	25	Drive Sleeve	Steel	AISI 1023
7	Stem Nut	Bronze	ASTM B584 C86700	17	Actuator Gasket	Rubber	NBR	26	Cover Bushing	Bronze	ASTM B584 C86700
9	O-ring	Rubber	NBR	18	Socket Head Bolt	Alloy Steel	Alloy Steel	27	Extension Bushing	Bronze	ASTM B584 C86700
10	Hex Head Bolt	Stainless Steel	ASTM F593-304	19	O-ring	Rubber	NBR	28	Thrust Bearing (18"-24")	Delrin	Delrin